

CARTS

PRESENT CART



ITEM # _____ MODEL # _____ QTY: _____
 PROJECT: _____
 OPTIONS: YES _____ NO _____



Standard Features & Benefits

- ◆ Highly versatile system is ideal for drive-thru and counter applications
- ◆ Solid stainless steel top, hanger rail and pulp tray holder are attractive, durable and easy-to-clean
- ◆ Three wire shelves deliver added storage and utility
- ◆ Includes four posts with easy-rolling 5" (127mm) resilient casters with brakes for maximum maneuverability, control and easy item transport
- ◆ Comes kit-packed for easy set-up

Model No.	W x L x H (in.)	W x L x H (mm)
WST1350C	12 x 36 x 35	305 x 910 x 889

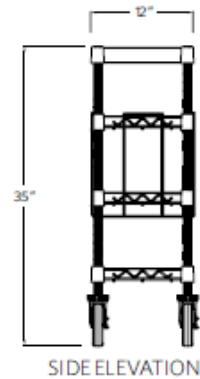
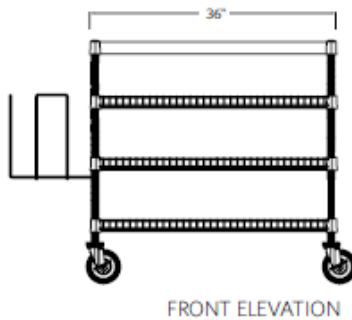

For SPG's complete product menu, visit www.spgusa.com or call 877.503.4SPG (4774)

